



MAKE YOU SAFER AND SMARTER SCISSOR LIFTS



ZMG INDUSTRIES (SUZHOU) CO., LTD.

Production Base 1

No.18, Xingye Road, Baochanshan Industrial Park, Ma'anshan City, Anhui Province, China, 23800

Production Base 2 & Sales Center

Weier Rd, Wuzhong Comprehensive Bonded Zone, Suzhou, China, 215000

Tel: 0086 512 65916195 Fax: 0086 512 65915205

Sales: info@zmglift.com Service: service@zmglift.com

www.zmglift.com



MAKE YOU SAFER & SMARTER

ZMG Industries (Suzhou) Co., Ltd reserves the right to make any changes without notice concerning colors, equipment or specifications detailed in this brochure, or to discontinue individual models. The configuration of equipment, delivered may differ slightly from those in brochures.



ZMG Industries (Suzhou) Co., Ltd.
www.zmglift.com

Safety First

ZMG always take safety as the first goal of our design concept. The products designed by us are always focused on the safety. It is our eternal pursue to provide safe products and unparalleled service with you. We are your reliable cooperative partner.

Smart & Intelligence is the Future

Our aerial work platform not only can lift you and your materials up to your expected height, but also can be your working partner, which can lift you up, help you move and keep you safe. Through our aerial work platform, cloud platform, and surrounding communication connection, we can know the working condition and date of the aerial work platform timely, then we can maintain and service our aerial work platform in time. The smart solution provided by us can monitor and diagnose our aerial work platform online.

Based on above concepts, we are trying to make our aerial work platform safer and smarter in design, manufacture, sale and service.

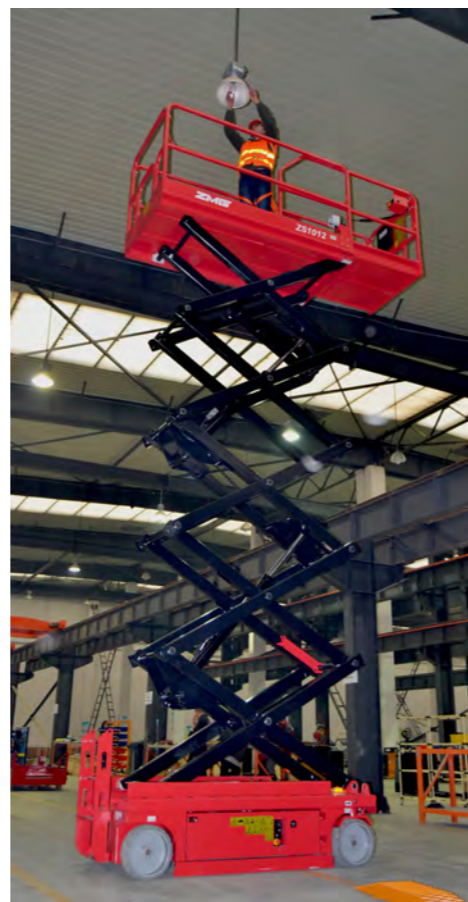

APPLICATIONS

Multi-purpose, for all types of work

ZMG electric and rough terrain scissor lifts with reliable quality, simple structure, high performance, makes operation safer, maintenance easier. Your best choice for higher reach. ZMG scissor lifts bring you high performance, versatility and high productivity. ZMG electric scissor lifts are exceptionally mobile, letting you maneuver on tight working space. They're productive and efficient, providing increased workspace for larger loads and more workers.

Ideal for finishing for construction works, interior industrial, outdoor maintenance and work, logistics and distribution etc.



**MAKE YOU
SAFER & SMARTER**



Compact Maneuverability

All ZMG scissor lifts models have dual front-wheel drive, and most models feature zero inside turning radius for excellent maneuverability in tight spaces like congested construction sites, elevators and narrow aisles. Compact scissor lifts can easily pass the standard single doorway and the double doorways.



Easy Maintenance

All ZMG scissor lifts are equipped with two swing-out trays for quick and easy maintenance. All parts in box can be directly accessible.



Indoor and Outdoor Work

ZMG electric scissor lifts are equipped with multifunctional performance at the outdoor firm flat ground. Its biggest gradeability is 30%, which can be widely used.



Noiseless and Environment protecting

ZMG electric scissor lifts are noiseless, non-pollution, environment protecting. From commercial constructions to hospitals, schools and facilities maintenance applications, ZMG scissor lifts can be used virtually anywhere there's work to be done. The highest working height of ZMG electric lifting platform is 14m, which is able to work aloft in the narrow areas.

Make You Safer

ZMG always puts safety first in the first place of our products' design concept. Whether they are lifted, lowered or working at height, ZMG scissor lifts' innovative pothole protection, emergency lowering device, safety bracket, and three-second delay descent function always can bring you a stronger sense of security.



Emergency Lowering system

In the event of power outage or emergency, the lifting platform can be lowered by manually pulling the emergency lowering device.



Tilt Alarm

When the tilt angle of the scissor lifts is greater than the safe value (tilt angle 3°, side tilt angle 1.5°), the safety system will alarm, and at the same time, scissor lifts will stop lifting and moving.

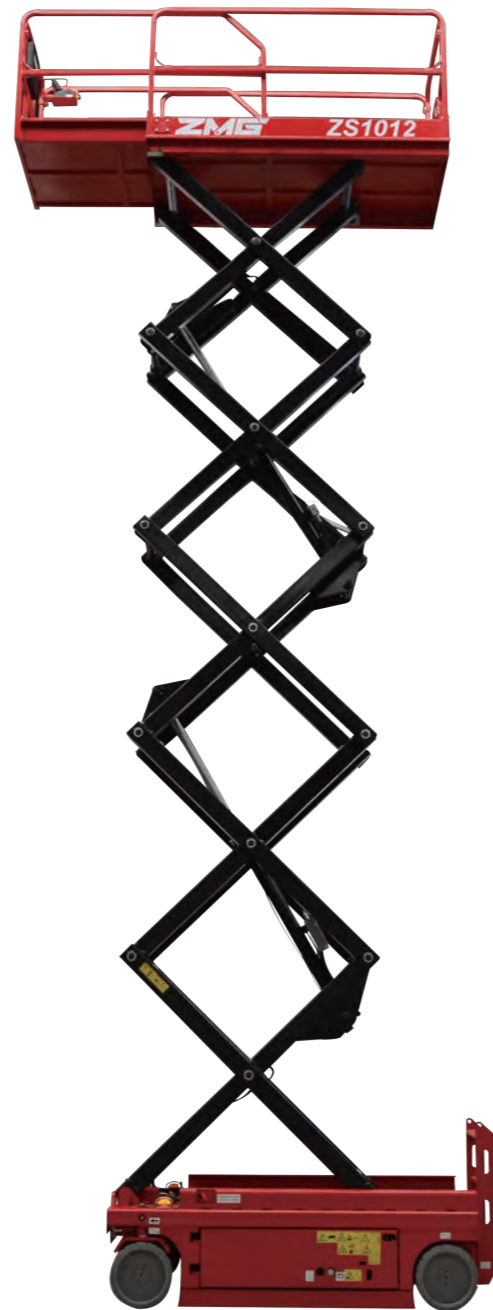

Safety Bracket

This device can ensure operator's safety when the operator is overhauling the scissor lifts.



Innovative Pothole Protection

Active pothole protection provides increased ground clearance, makes movement and operation more stable and safer.

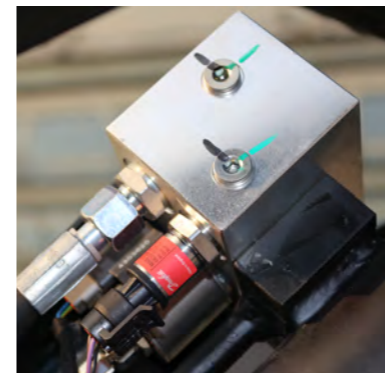

Overload Protection

When the platform is overloaded , the overload protection system will alarm, and at the same time, scissor lifts will stop lifting and moving.



Make You Smarter

ZMG scissor lift is equipped with the most advanced Delta Tech control system. Its operation box is easy to be carried, which can be operated out of the platform, makes the operation more flexible. Its error code can be read easily, which makes it easier for users to analyze the cause of the problem, then solve the problem more efficiently and quickly.



Flexible extended platform

Extended platform can be pushed easily and smoothly, saves energy and time of operators, improves productivity.



Zero inside turning radius

Zero inside turning radius makes possible precision movements in especially difficult places, while insuring the safety of its operators. It's turning radius is extremely narrow , so the operator can maneuver in the most restricted spaces.



Non-Marking Tires

ZMG uses solid rubber non-marking tires on scissor lifts. These tires can prevent polluting floor or damaging to the floor. It's quite suitable for indoor work.



Delta Tech Control System

With Delta Tech PCU and ECU, ZMG scissor lifts can be operated more easily and flexibly, which maximize your productivity. Sensitive fault detection can analyze the malfunction timely, makes troubleshooting easier.

Strong Gradeability

ZMG scissor lifts can get over numerous obstacles and has no trouble making it up truck ramps during the transport phase. The gradeability can be up to 25-45% (Gradeability may vary depending on models and options installed on machine.)

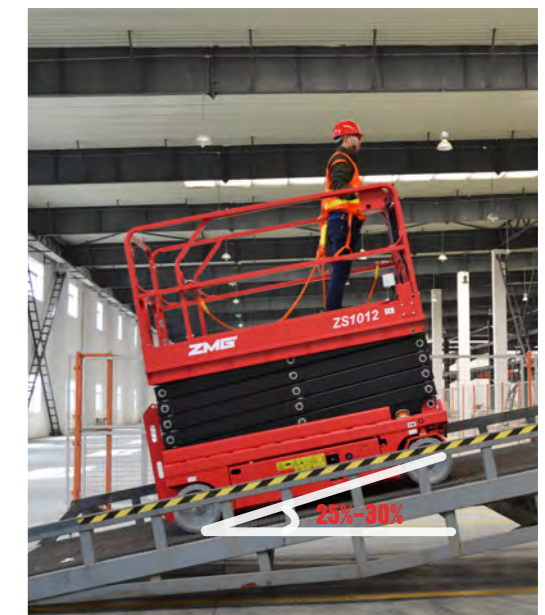

Make You Easier

While improving users' working efficiency, ZMG scissor lifts apply humanized design, which saves users time and efforts on maintenance spaces, working at height, passing through narrow channels, and other circumstances.



AC Power to Platform

ZMG scissor lifts are equipped with AC power to platform, which greatly improve your work efficiency



Brake Release Device

In case of power failure, scissor lifts are locked and they can be unlocked by pressing the brake release button.



Quick Maintenance

ZMG scissor lifts are equipped with two swing-out trays for quick and easy maintenance:

- 1 tray for the batteries.
- 1 tray for hydraulic and electrical systems.



Dual Flashing Beacons

Orange flashing lights warn workers when lift is moving or in operation.



Specifications

Self-Propelled Scissor Lift

MODEL	WORKING HEIGHT		WIDTH		TURNING RADIUS*		LIFT CAPACITY		GRADEABILITY**
	US	METRIC	US	METRIC	US	METRIC	US	METRIC	
Electric Scissor Lifts									
ZS0407	21 ft 5 in	6.52 m	2 ft 6 in	0.76 m	5 ft 1 in	1.55 m	617 lbs	280 kg	30%
ZS0407W	21 ft 5 in	6.52 m	2 ft 8 in	0.81 m	4 ft 5 in	1.35 m	617 lbs	280 kg	30%
ZS0607	25 ft 7 in	7.80 m	2 ft 6 in	0.76 m	4 ft 5 in	1.35 m	507 lbs	230 kg	25%
ZS0607W	25 ft 7 in	7.80 m	2 ft 8 in	0.81 m	4 ft 5 in	1.35 m	507 lbs	230 kg	25%
ZS0612	26 ft 11 in	8.20 m	3 ft 9 in	1.15 m	7 ft 7 in	2.30 m	1213 lbs	550 kg	30%
ZS0812	33 ft 2 in	10.10 m	3 ft 9 in	1.15 m	7 ft 7 in	2.30 m	1014 lbs	460 kg	30%
ZS1012	39 ft 3 in	11.96 m	3 ft 9 in	1.15 m	7 ft 7 in	2.30 m	705 lbs	320 kg	25%
ZS1212	45 ft 10 in	13.96 m	3 ft 9 in	1.15 m	7 ft 7 in	2.30 m	705 lbs	320 kg	25%
Rough Terrain Scissor Lifts									
ZS1623RT	59 ft 1 in	18 m	7 ft 6 in	2.29 m	17 ft 1 in	5.20 m	1500 lbs	680 kg	45%

* Outside Radius

** Gradeability applies to driving on slopes, see operator's manual for details regarding slope ratings. Gradeability may vary depending on options installed on machine

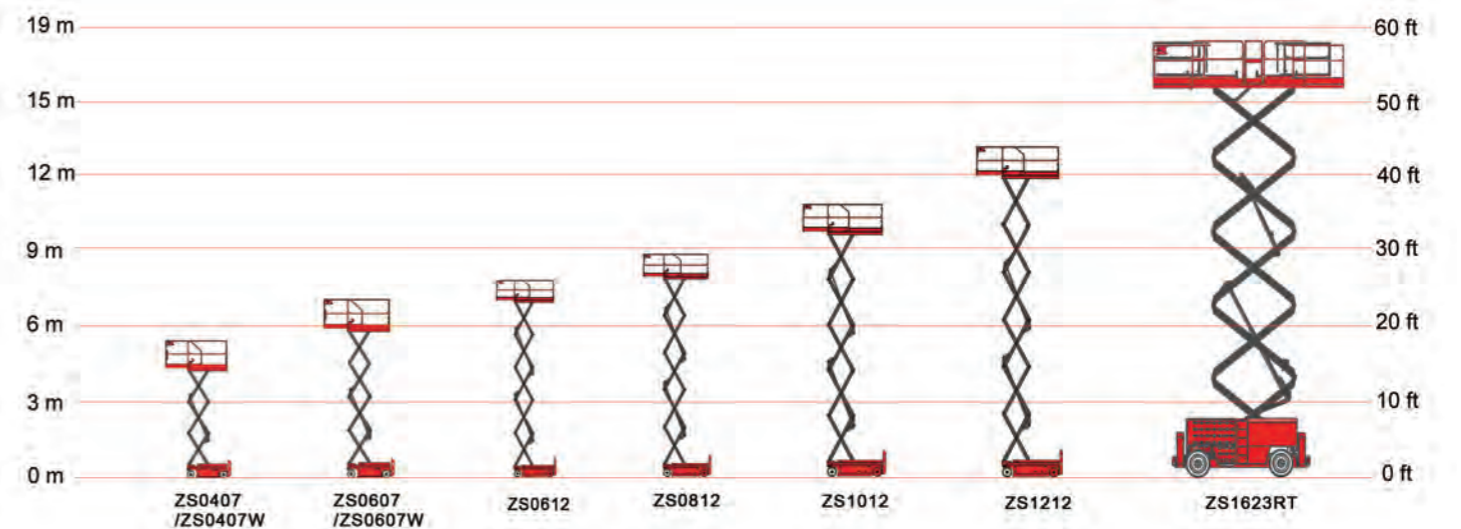

ZS0407 / ZS0407W

Models	ZS0407		ZS0407W	
Measurements	US	Metric	US	Metric
A Working height maximum*	21ft 5 in	6.52 m	21ft 5 in	6.52 m
A Platform height maximum	14ft 10 in	4.52 m	14ft 10 in	4.52 m
B Length-stowed	6 ft 1 in	1.86 m	6 ft 1 in	1.86 m
C Width	2 ft 6 in	0.76 m	2 ft 8 in	0.81 m
D Height stowed fixed rails	6 ft 9 in	2.06 m	6 ft 9 in	2.06 m
E Platform length -Outside	5 ft 5 in	1.65 m	5 ft 5 in	1.65 m
F Slide-out platform extension deck	2 ft 11 in	0.90 m	2 ft 11 in	0.90 m
G Platform width - outside	2 ft 6 in	0.76 m	2 ft 6 in	0.76 m
H Wheelbase	4 ft 5 in	1.35 m	4 ft 5 in	1.35 m
I Ground clearance-center	2.4 in	0.06 m	2.4 in	0.06 m
J - with pothole guards deployed	0.80 in	0.02 m	0.80 in	0.02 m
Productivity				
Maximum Platform Occupancy **	2	2	1	1
Lift capacity	617 lbs	280 kg	617 lbs	280 kg
Lift capacity - extension deck	265 lbs	120 kg	265 lbs	120 kg
Drive height	full height			
Drive speed - stowed	2.5 mph	4.0 km/h	2.5 mph	4.0 km/h
Drive speed - raised	0.5 mph	0.8 km/h	0.5 mph	0.8 km/h
Gradeability - stowed***	30%			
Turning radius - inside	0			
Turning radius - outside	5 ft 1 in	1.55 m	4 ft 5 in	1.35 m
Max. work angle of inclination	3°/ 1.5°			
Raise / lower speed (s)	18/28			
Controls	Proportional			
Drive	Dual front wheel			
Multiple disc brakes	Dual rear wheel			
Tires - solid non-marking	12 x 4 in	30.5x11.4cm	12 x 4 in	30.5x11.4cm
Power				
Drive Motor	3.3 kw			
Power source	24 V DC (four 6 V 225 Ah batteries)			
Charger	90-240 V 25 Amp			
Hydraulic system capacity	2.6 gal	10 L	2.6 gal	10 L
Weight****	2723 lbs	1,235 kg	2734 lbs	1,240 kg

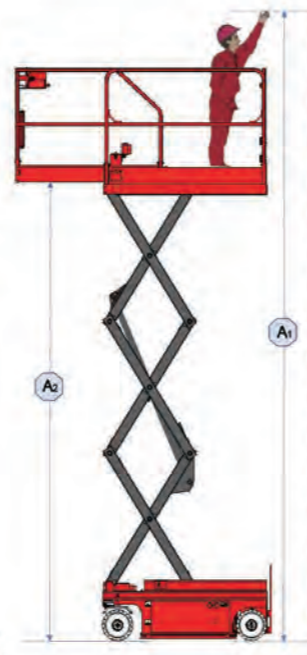
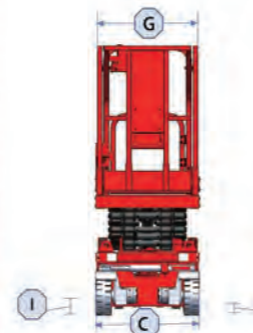
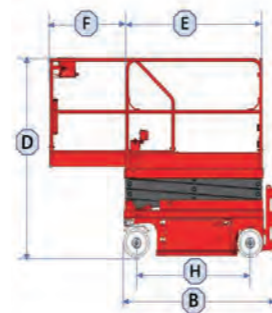

Standard Equipment

- Auto brake system
- Manual braking release
- Emergency lowering
- Lanyard attachment points
- Emergency stop at both platform and ground controls
- Hour meter
- Drive flashing beacons
- Motion alarm
- Electronic horn
- Descent alarm
- Descent protection
- Charging position regulation
- Tilt level sensor with audible alarm
- Overload protection system
- On-board diagnosis system
- Oil pipeline explosion-proof
- Pothole protection
- Safety brackets

Options & Accessories

- AC power to platform
- Airline to platform
- GPS module
- Obstacle alarm
- AGM maintenance free batteries
- Charging protection
- Platform flashing beacons

ZS0607 / ZS0607W

Models	ZS0607		ZS0607W	
Measurements	US	Metric	US	Metric
A Working height maximum*	25 ft 7 in	7.8 m	25 ft 7 in	7.8 m
A Platform height maximum	19 ft	5.8 m	19 ft	5.8 m
B Length-stowed	6 ft 1 in	1.86 m	6 ft 1 in	1.86 m
C Width	2 ft 6 in	0.76 m	2 ft 8 in	0.81 m
D Height stowed fixed rails	7 ft 2 in	2.18 m	7 ft 2 in	2.18 m
E Platform length -Outside	5 ft 5 in	1.65 m	5 ft 5 in	1.65 m
F Slide-out platform extension deck	2 ft 11 in	0.90 m	2 ft 11 in	0.90 m
G Platform width - outside	2 ft 6 in	0.76 m	2 ft 6 in	0.76 m
H Wheelbase	4 ft 5 in	1.35 m	4 ft 5 in	1.35 m
I Ground clearance-center	2.4 in	0.06 m	2.4 in	0.06 m
J - with pothole guards deployed	0.80 in	0.02 m	0.80 in	0.02 m
Productivity				
Maximum Platform Occupancy **	2	2	1	1
Lift capacity	507 lbs	230 kg	507 lbs	230 kg
Lift capacity - extension deck	265 lbs	120 kg	265 lbs	120 kg
Drive height	full height			
Drive speed - stowed	2.5 mph	4.0 km/h	2.5 mph	4.0 km/h
Drive speed - raised	0.5 mph	0.8 km/h	0.5 mph	0.8 km/h
Gradeability - stowed***	25%			
Turning radius - inside	0			
Turning radius - outside	4 ft 5 in	1.35 m	4 ft 5 in	1.35 m
Max. work angle of inclination	3°/ 1.5°	3°/ 1.5°	3°/ 1.5°	3°/ 1.5°
Raise / lower speed (s)	18/28			
Controls	Proportional			
Drive	Dual front wheel			
Multiple disc brakes	Dual rear wheel			
Tires - solid non-marking	12 x 4.3 in	30.5x11.4cm	12 x 4.3 in	30.5x11.4cm
Power				
Drive Motor	3.3 kw			
Power source	24 V DC (four 6 V 225 Ah batteries)			
Charger	90-240 V 25 Amp		90-240 V 25 Amp	
Hydraulic system capacity	2.6 gal	10 L	2.6 gal	10 L
Weight****	3263 lbs	1480 kg	3307 lbs	1500 kg

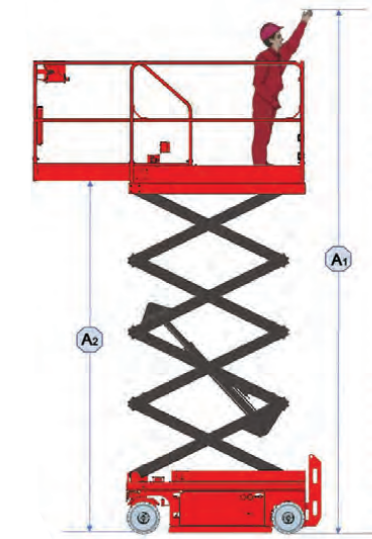
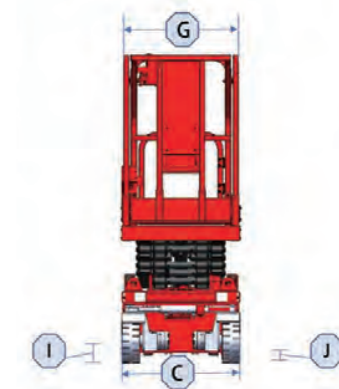
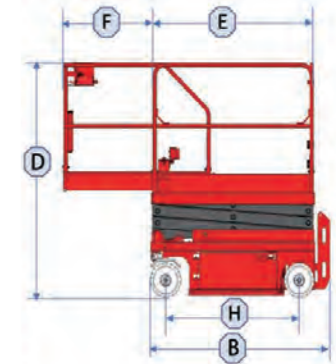

Standard Equipment

- Auto brake system
- Manual braking release
- Emergency lowering
- Lanyard attachment points
- Emergency stop at both platform and ground controls
- Hour meter
- Drive flashing beacons
- Motion alarm
- Electronic horn
- Descent alarm
- Descent protection
- Charging position regulation
- Tilt level sensor with audible alarm
- Overload protection system
- On-board diagnosis system
- Oil pipeline explosion-proof
- Pothole protection
- Safety brackets

Options & Accessories

- AC power to platform
- Airline to platform
- GPS module
- Obstacle alarm
- AGM maintenance free batteries
- Charging protection
- Platform flashing beacons

ZS0612 / ZS0812

Models	ZS0612		ZS0812	
	US	Metric	US	Metric
Measurements				
A Working height maximum*	26 ft 11 in	8.2 m	33 ft 2 in	10.10 m
A ₂ Platform height maximum	20 ft 4 in	6.2 m	26 ft 7 in	8.10 m
B Length-stowed	8 ft 1 in	2.47 m	8 ft 1 in	2.47 m
C Width	3 ft 9 in	1.15 m	3 ft 9 in	1.15 m
D Height stowed fixed rails	7 ft 3 in	2.22 m	7 ft 8 in	2.34 m
Height stowed-rails foiled	3 ft 2 in	1.58 m	5 ft 7 in	1.70 m
E Platform length -Outside	7 ft 5 in	2.27 m	7 ft 5 in	2.27 m
F Slide-out platform extension deck	3 ft 3 in	1 m	3 ft 3 in	1 m
G Platform width - outside	3 ft 9 in	1.15 m	3 ft 9 in	1.15 m
H Wheelbase	6 ft 1 in	1.85 m	6 ft 1 in	1.85 m
I Ground clearance-center	4 in	0.1 m	4 in	0.10 m
J - with pothole guards deployed	0.8 in	0.02 m	0.80 in	0.02 m
Productivity				
Maximum Platform Occupancy **	2	2	2	2
Lift capacity	1213 lbs	550 kg	1014 lbs	460 kg
Lift capacity - extension deck	265 lbs	120 kg	265 lbs	120 kg
Drive height	full height			
Drive speed - stowed	2.2 mph	3.5 km/h	2.2 mph	3.5 km/h
Drive speed - raised	0.5 mph	0.8 km/h	0.5 mph	0.8 km/h
Gradeability - stowed***	30%		30%	
Turning radius - inside	0		0	
Turning radius - outside	7 ft 7 in	2.3 m	7 ft 7 in	2.3 m
Max. work angle of inclination	3°/ 1.5°		3°/ 1.5°	
Raise / lower speed (s)	28/28		28/28	
Controls	Proportional			
Drive	Dual front wheel			
Multiple disc brakes	Dual rear wheel			
Tires - solid non-marking	15 x 5 in	38 x 13 cm	15 x 5 in	38 x 13 cm
Power				
Drive Motor	3.3kw		3.3 kw	
Power source	24 V DC (four 6 V 225 Ah batteries)			
Charger	90-240V 25 Amp		90-240V 30 Amp	
Hydraulic system capacity	5.8 gal	22 L	5.8 gal	22 L
Weight****	5185 lbs	2350 kg	5401 lbs	2450 kg

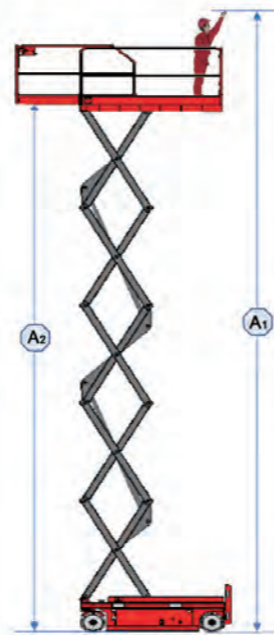
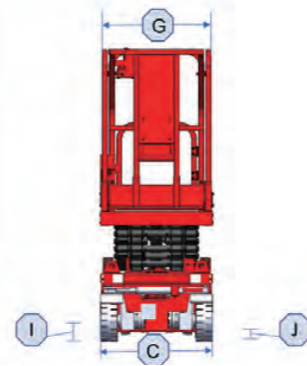
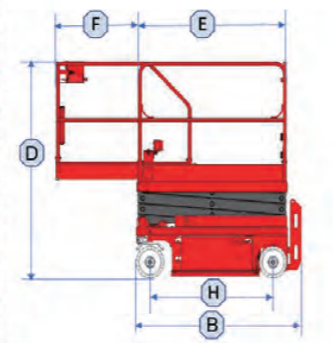

Standard Equipment

- Auto brake system
- Manual braking release
- Emergency lowering
- Lanyard attachment points
- Emergency stop at both platform and ground controls
- Hour meter
- Drive flashing beacons
- Motion alarm
- Electronic horn
- Descent alarm
- Descent protection
- Charging position regulation
- Tilt level sensor with audible alarm
- Overload protection system
- On-board diagnosis system
- Oil pipeline explosion-proof
- Pothole protection
- Safety brackets

Options & Accessories

- Folding rails on platform
- AC power to platform
- Airline to platform
- GPS module
- Obstacle alarm
- AGM maintenance free batteries
- Charging protection
- Platform flashing beacons

ZS1012 / ZS1212

Models	ZS1012		ZS1212	
	US	Metric	US	Metric
Measurements				
A Working height maximum*	39 ft 3 in	11.96 m	45 ft 10 in	13.96 m
A ₂ Platform height maximum	32 ft 8 in	9.96 m	39 ft 3 in	11.96 m
B Length-stowed	8 ft 1 in	2.47 m	8 ft 1 in	2.47 m
C Width	3 ft 9 in	1.15 m	3 ft 9 in	1.15 m
D Height stowed fixed rails	8 ft 1 in	2.47 m	8 ft 6 in	2.60 m
Height stowed-rails folded	6 ft	1.83 m	6 ft 5 in	1.95 m
E Platform length -Outside	7 ft 5 in	2.27 m	7 ft 5 in	2.27 m
F Slide-out platform extension deck	3 ft 3 in	1 m	3 ft 3 in	1 m
G Platform width - outside	3 ft 9 in	1.15 m	3 ft 9 in	1.15 m
H Wheelbase	6 ft 1 in	1.85 m	6 ft 1 in	1.85 m
I Ground clearance-center	4 in	0.10 m	4 in	0.10 m
J - with pothole guards deployed	0.80 in	0.02 m	0.80 in	0.02 m
Productivity				
Maximum Platform Occupancy **	2	2	1	1
Lift capacity	705 lbs	320 kg	705 lbs	320 kg
Lift capacity - extension deck	265 lbs	120 kg	265 lbs	120 kg
Drive height	full height			
Drive speed - stowed	2.2 mph	3.5 km/h	2 mph	3.2 km/h
Drive speed - raised	0.5 mph	0.8 km/h	0.5 mph	0.8 km/h
Gradeability - stowed***	25%		25%	
Turning radius - inside	0		0	
Turning radius - outside	7 ft 7 in	2.3 m	7 ft 7 in	2.3 m
Max. work angle of inclination	3°/ 1.5°		3°/ 1.5°	
Raise / lower speed (s)	58/48		70/68	
Controls	Proportional			
Drive	Dual front wheel			
Multiple disc brakes	Dual rear wheel			
Tires - solid non-marking	15 x 5 in	38 x 13 cm	15 x 5 in	38 x 13 cm
Power				
Drive Motor	3.3 kw		4.5 kw	
Power source	24 V DC (four 6 V 225 Ah batteries)			
Charger	90-240V 25 Amp			
Hydraulic system capacity	5.8 gal	22 L	5.8 gal	22 L
Weight****	6173 lbs	2800 kg	6878 lbs	3120 kg

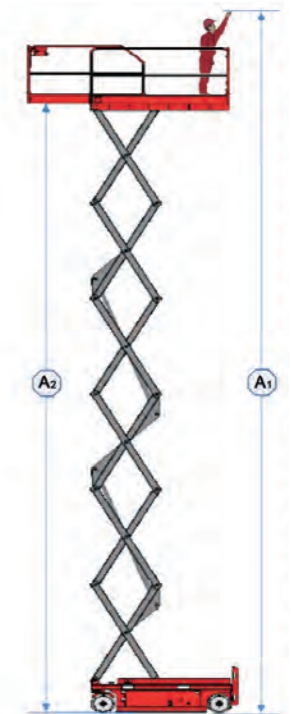
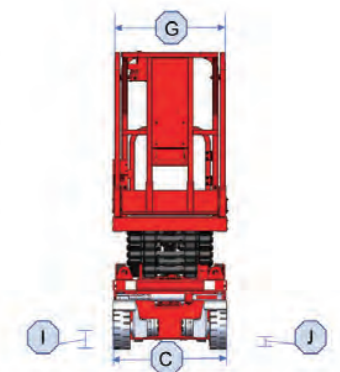
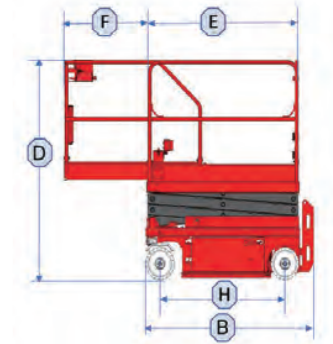

Standard Equipment

- Auto brake system
- Manual braking release
- Emergency lowering
- Lanyard attachment points
- Emergency stop at both platform and ground controls
- Hour meter
- Drive flashing beacons
- Motion alarm
- Electronic horn
- Descent alarm
- Descent protection
- Charging position regulation
- Tilt level sensor with audible alarm
- Overload protection system
- On-board diagnosis system
- Oil pipeline explosion-proof
- Pothole protection
- Safety brackets

Options & Accessories

- Folding rails on platform
- AC power to platform
- Airline to platform
- GPS module
- Obstacle alarm
- AGM maintenance free batteries
- Charging protection
- Platform flashing beacons

ZS1623RT

Models	ZS1623RT	
Measurements	US	Metric
A Working height maximum*	59 ft 1 in	18 m
A ₂ Platform height maximum	52 ft 6 in	16 m
B Length-stowed	16 ft	4.88 m
C Width	7 ft 6 in	2.29 m
D Height-stowed rails	10 ft 4 in	3.15 m
Height-extend rails	8 ft 1 in	2.47 m
E Platform length -Outside	13 ft 1 in	3.98 m
F Slide-out platform extension deck(front)	4 ft 12 in	1.52 m
G Slide-out platform extension	4 ft 12 in	1.52 m
H Platform width - outside	6 ft	1.83 m
I Wheelbase	9 ft 4 in	2.85 m
J Ground clearance-center	1ft 2 in	0.36 m
Productivity		
Maximum Platform Occupancy **	6	6
Lift capacity	1500 lbs	680 kg
Lift capacity - extension deck	500 lbs	227 kg
Drive height	29 ft 10 in	9.10 m
Drive speed - stowed	3.8 mph	6 km/h
Drive speed - raised	0.4 mph	0.7 km/h
Gradeability - stowed***		45%
Turning radius - inside	7 ft 3 in	2.20 m
Turning radius - outside	17 ft 1 in	5.20 m
Max. work angle of inclination		7°/ 12°
Raise / lower speed (s)		60/60
Controls		proportional
Drive		four wheel
Multiple disc brakes		four wheel
Tires - solid non-marking	12 x 33 in	30 x 84 cm
Power		
Power source		36 kw
Auxiliary Power unit		12 V DC
Hydraulic system capacity	34 gal	130 L
Weight****	16645 lbs	7550 kg

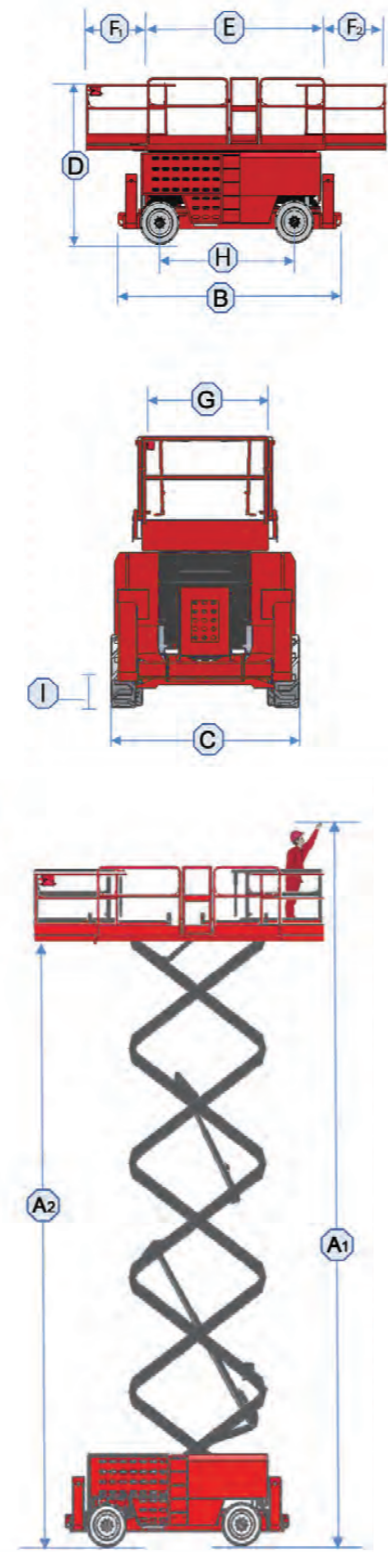

Standard Equipment

- Auto brake system
- Emergency pump
- Lanyard attachment points
- Emergency stop
- Drive flashing beacons
- Motion alarm
- Electronic horn
- Descent alarm
- Descent protection
- Tilt level sensor with audible alarm
- Overload protection system
- On-board diagnosis system
- Oil pipeline explosion-proof
- Folding rails on platform
- Safety brackets

Options & Accessories

- Hydraulic-engine set
- Airline to platform
- GPS module
- Obstacle alarm
- Platform flashing beacon
- Outriggers

Smart Management and Remote Control System

This system contains hardware like Platform Control Unit (PCU), Engine Control Unit (ECU) and other controllers, and integrates smart modular software. The ECU is integrated by sensors, potentiometers, and communication modules,

With software application, following functions are realized:

- Smart equipment control (e.g. auto path planning, auto equipment setting up, battery management)
- Equipment remote control (remote monitoring and diagnosis, rental management)

Application Example:

Equipment Internet

Use wireless WIFI, GPS, and mobile internet and cloud platform, to track equipment location, diagnose equipment from inhouse.

Rental Management System

Rental company can use PC, Phone or Pad to logon relevant APP or web-based system to track equipment location, diagnose equipment, make time management, manage rental rate, control dynamic passwords and conduct data analysis of the rental fleet, to optimize rental rate and utilization rate.

